

# SPIRIT

## Phase 3 – TekBot Motor Testing

### Computer and Electronics Engineering

#### Purpose

You will continue adding components to your TekBot™ ending with a Bot that will run.

#### Overview

During the course of this lab you will perform the following tasks:

- Assemble more components for your TekBot.
- Learn basic ideas about how a DC motor operates.

#### Pre-project

Be sure your TekBot is fully charged before coming to lab. To do this be sure that your TekBot has been plugged into the wall for at least 8 hours prior to lab. If your instructor has not looked at your system yet make sure she does BEFORE you plug it and try to charge it.

#### ➤ Make Power Cables

- **Description:**
  - **Four-pin Male Header – One on Each End**
  - **Two wires**
- **Warning:**
  - **Don't Cross Wires-Same Wire on Outside Pin of Both Connectors**

#### Procedure

1. You will need to make a power cable for your robot to get power from your batteries to your protoboard. The TekBot has a 'keyed' connector system for power. This means that to work correctly you can only insert your power cables one way. This will help protect your TekBot. An example of this can be seen in Figure 1. The cable is constructed from two four-position male

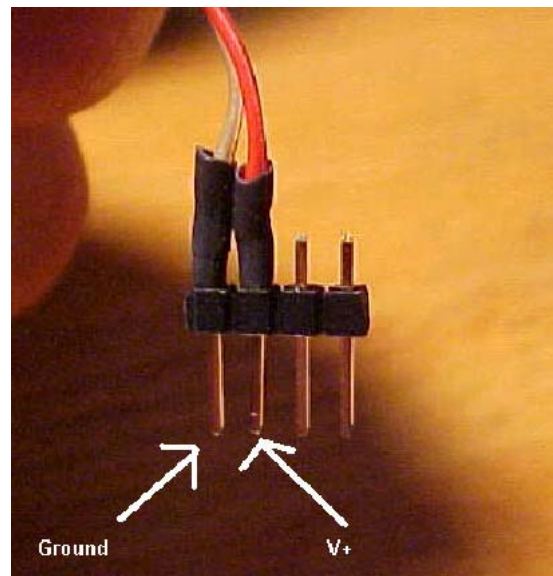
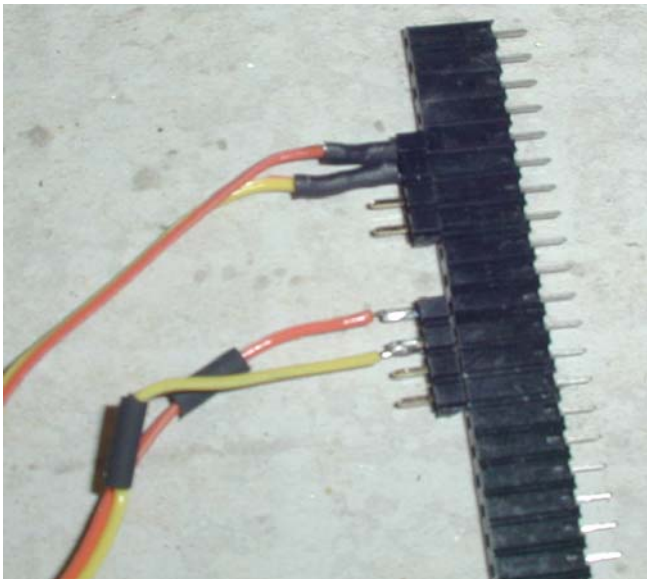

Figure 1 Power Cable Connector

headers on each end of a two wire cable. Only two of the pins on each connector are used. Make sure that the wires are connected to corresponding pins on both connectors. Figure 2 shows the cable. A female connector strip is used to hold the male connectors while soldering. When soldering wires to the connectors, I recommend tinning the wire and the pin first. Additional solder is usually not needed when you solder the wire to the pin.

2. Insert one end of the cable into the female sockets on the charger board. The two unused male pins on the connector will be over the unused holes on the charger board. See Figure 3.



**Figure 2 Using Female Connector to Hold Male Connectors While Soldering**

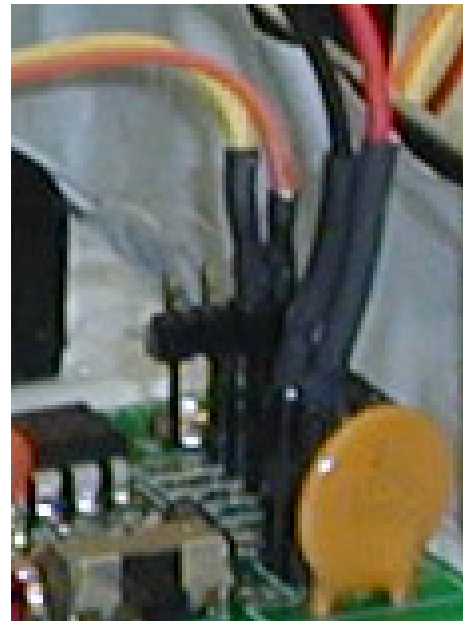

**Figure 3**

3. If you have not already mounted connectors onto the motor leads, solder 2-pin male connectors onto the leads for both motors.

## ➤ Attach Prototyping Board

- **Description:**

- Use Figure 7 to Determine Mounting Location. Use the ½” Hole as reference

- **Warning:**

- Don't Use the Adhesive on the Board to Mount It.

4. To assemble circuits quickly for prototyping a device called a 'breadboard' (or 'proto-board' ) is often used. Components can be easily inserted into a set of holes and connected together with wire. Locate the breadboard in your kit and remove it from the box. Now you need to make sure that the internal contacts are firmly seated. You do this by pushing on the backside of the board with your thumbs; Figure 6 shows how this is done.



**Figure 4 Breadboard**

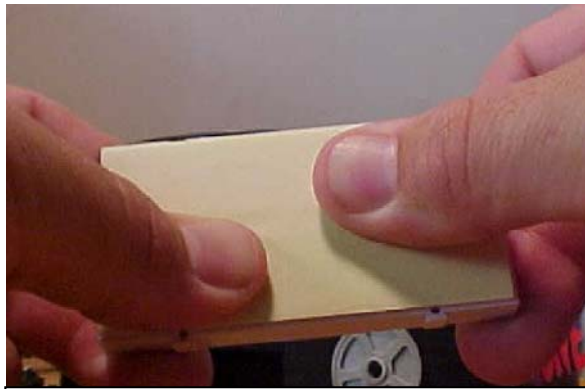
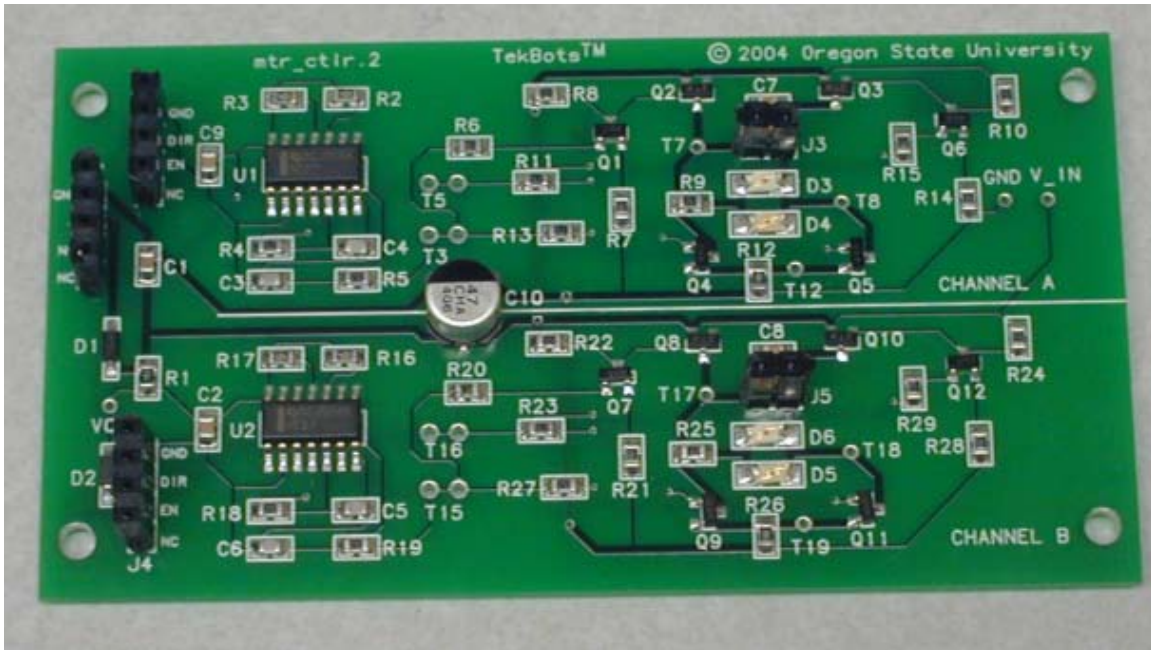

**Figure 5 Seating a Breadboard's Contacts**

**IT IS NOT RECOMMENDED THAT YOU USE THE DOUBLE SIDED STICKY TAPE ON THE PROTOBOARD. THIS WILL MAKE THE PROTOBOARD HARD TO RELOCATE IF YOU EVER NEED TO.**

5. Now you can affix the breadboard to your robot. Use the 4-40 5/8” metal machine bolts, and force them through the holes in the breadboard. This then attaches to the Plexiglas layer in your kits. See Figure 7 for placement.

## ➤ Mount the Motor Control Board



**Figure 6. Motor Control Board with Connectors**

6. Insert the screws into the printed circuit board. Put a small piece of tape over the head of each screw so it doesn't fall out when you turn the board over. Turn the board over and place spacers onto the screws. Place the Plexiglas over the spacers and attach with the nuts.

## ➤ Attach Plexiglass to Chassis

- **Warning:**

- **Plug Power Cable into Charger Board and Thread through Hole in Plexiglass before Mounting.**

7. The Plexiglas layer attaches to the base of your robot using 8-32 Nylon bolts and the nylon standoffs. Bring the wires from the motors and the power cable through the hole in the Plexiglas. Figure 7 shows the placement of the breadboard and motor control board on the Plexiglas.

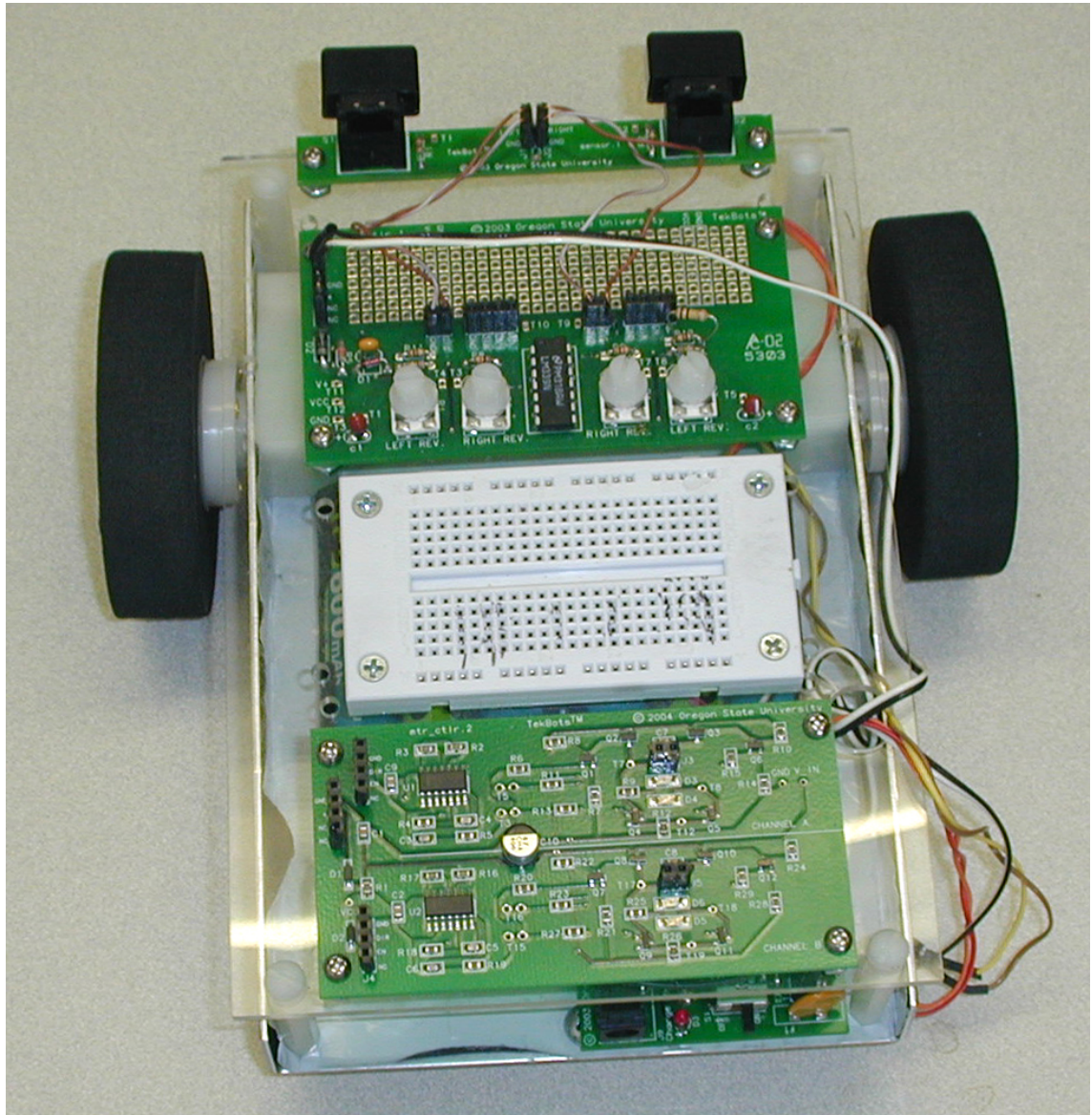

Figure 7. Motor Control Board and Breadboard

## ➤ Test the Motors

- **Warning:**

- **Orient the Power Cable Correctly in Proto Board - If You Do It Wrong You Will Fry The Batteries.**

8. Turn the switch on the charger board to "OFF". Looking at the TekBot from the front or back, insert the power plug horizontally into the breadboard. Make sure each pin is in a

separate node. If you have the plug rotated 90 degrees, you will short the batteries to ground. (This is bad!) Connect one of the motor cables to the breadboard in the same nodes as the power and ground of the power plug. See Figure 8. Move the charger switch to “ON”. One of the wheels should turn to make the TekBot go forward. If it

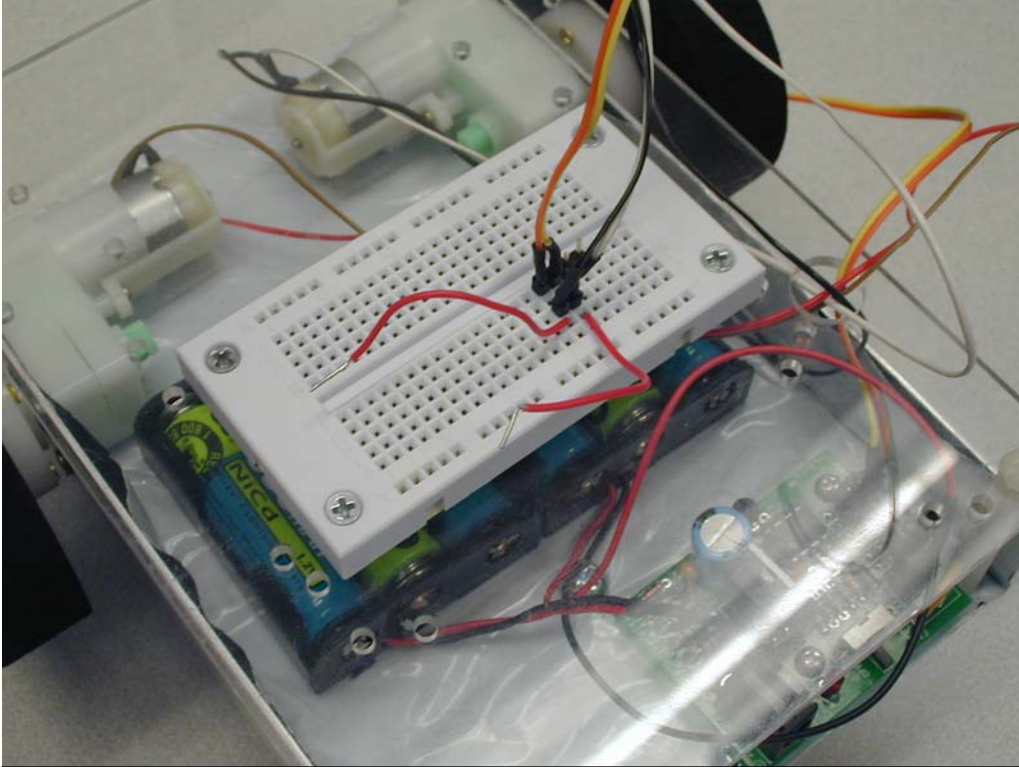

**Figure 8 Cable Positions for Testing Motors (Motor control removed for clarity)**

goes backwards, rotate the motor plug 180 degrees. Repeat for the other wheel. Connect both motor cables and run the TekBot on the floor. Observe how straight it goes.

## ➤ **Make Two More Cables**

- **Description:**

- **Four-pin Male Header – One on Each End**
- **Three Wires – about 9” Long**

- **Warning:**

- **Don’t Cross Wires-Same Wire on Outside Pin of Both Connectors**

## ➤ Test Motor Control Board

9. Remove connections to the protoboard. Connect the power cable from the charger board into J1 of the motor control board. Connect the right motor wires into J3 and the left motor wire into J5. Note that this is a FRONT WHEEL drive robot.

The motor board can perform three functions with each motor: forward, reverse, and stop. These functions are controlled by the two inputs for each motor.

To test the function of your motor controller you will place one of your three conductor cables from J2 to the protoboard as shown in Figure 9.

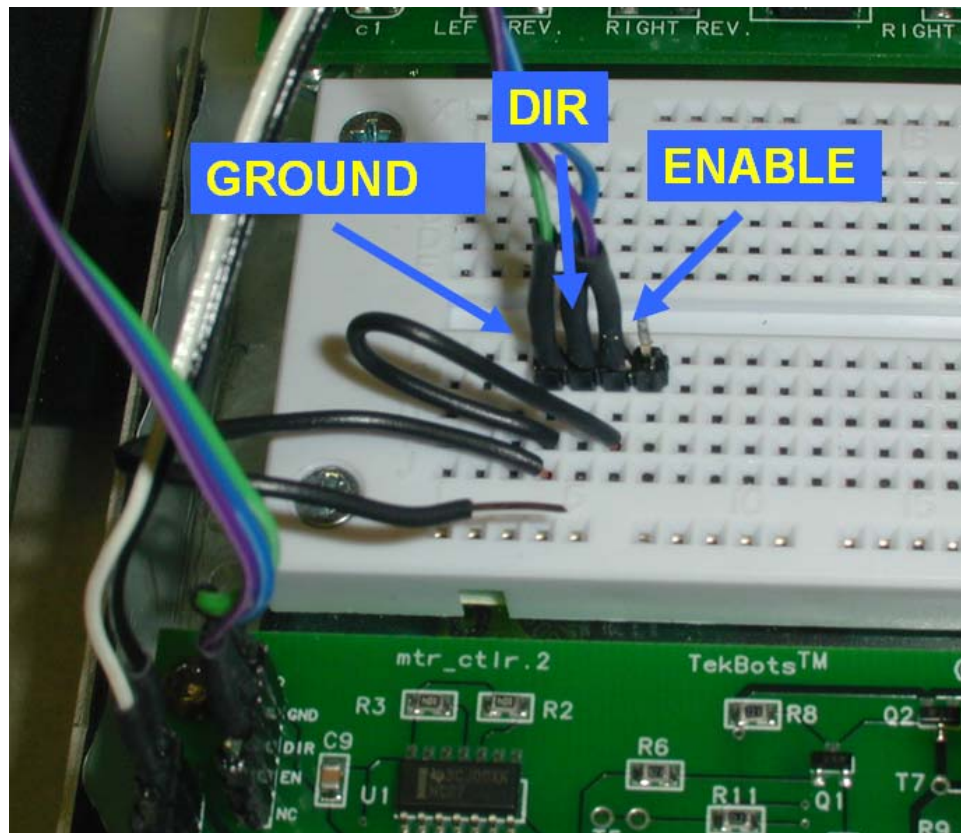

Figure 9

10. Place a wire from the Ground to the Enable. The right wheel should turn forward. A green LED on the control board should also turn on. If the wheel goes backwards but the green LED is on, reverse the motor cable in J3. Place a wire from Ground to Dir (don't remove the Enable wire). The wheel should turn backwards and the red LED should light.
11. Remove the cable from J2 and place in J4 and test the left wheel in the same manner.

## Use Wired Remote Control

- Place the cables from J4 and J2 from the Motor Control board on the prototype board as shown in Figure 10.

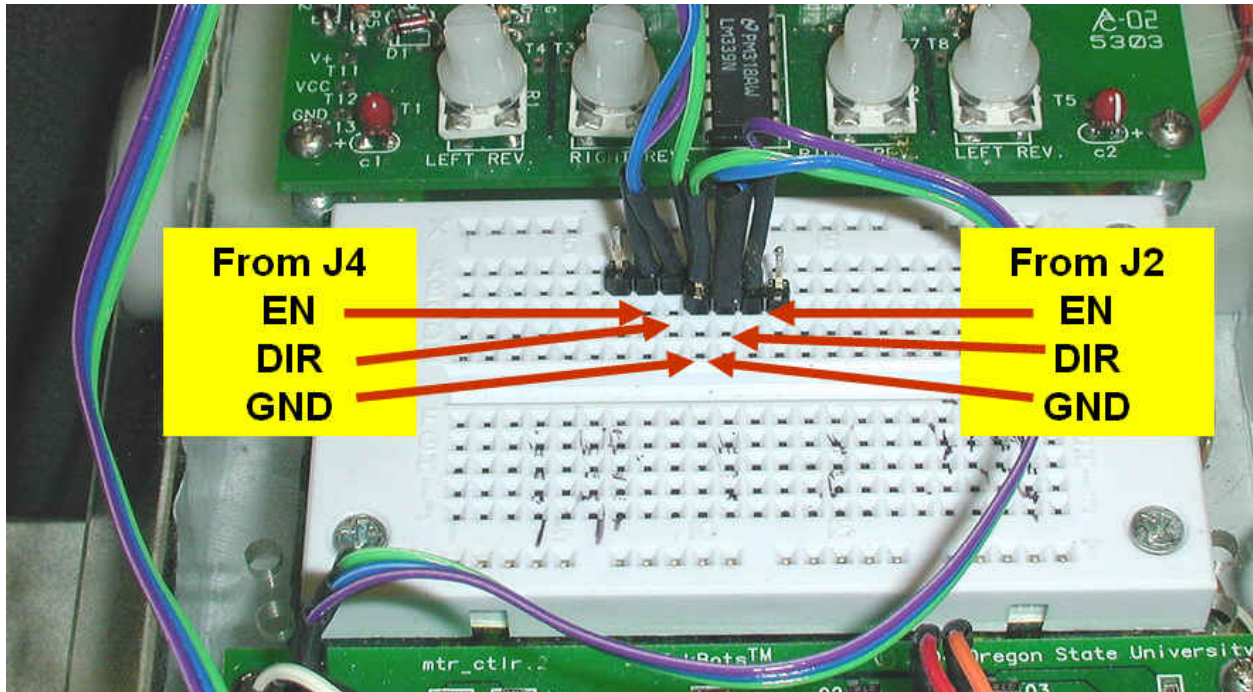

Figure 10. Wired Remote Control

- Place the plug from the wired remote control into the breadboard as shown in Figure 11. Move the charger board switch to ON. The TekBot right wheel should go forward when you press the right switch forward and go backward when you press the switch back. If the TekBot goes the opposite direction, rotate the plug from the motor 180 degrees. The left wheel should work in the same manner.



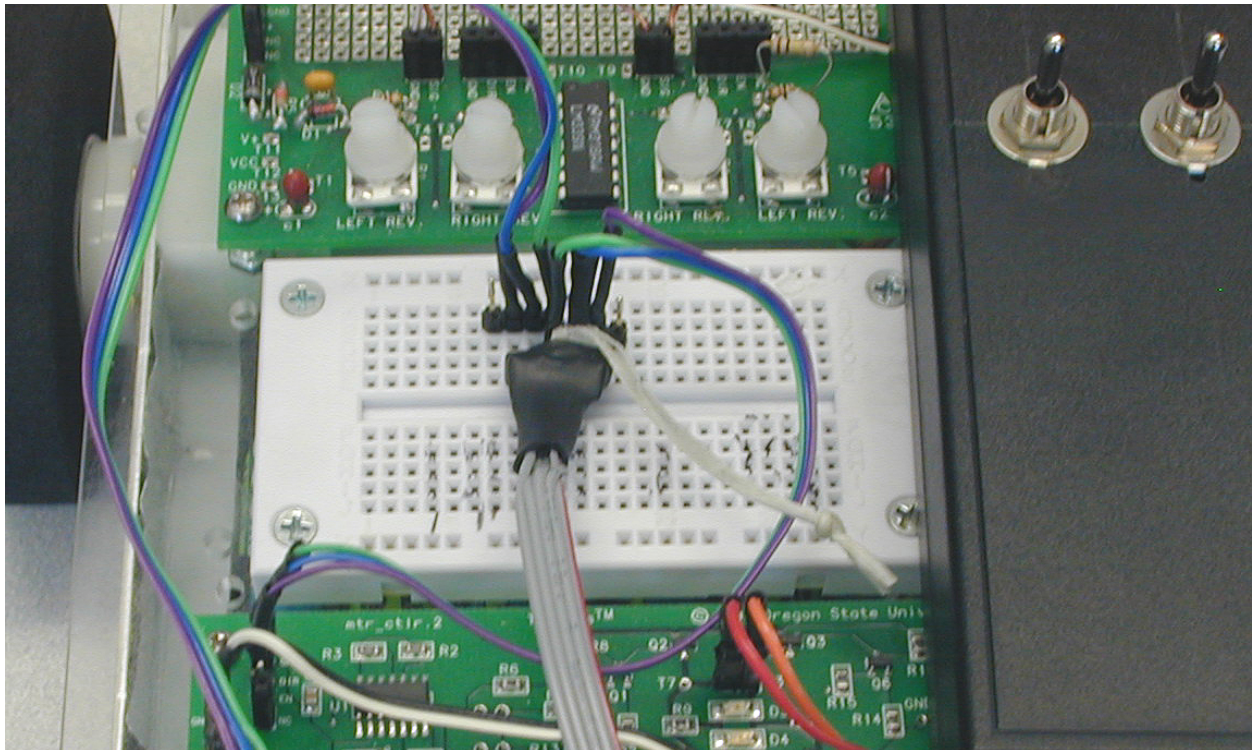

Figure 11. Remote Control Plug

Copyright C 2007  
University of Nebraska

This document is based on documents that are the property of Oregon State University and the School of EECS. Limited use is allowed according to the following criteria; materials are free to use except for cost of reproduction but must bear this statement. Materials created using this information may not be labeled as TekBots materials with out the prior written consent of Oregon State University and the School of EECS.